



AVK SUPA PLUS™ FLANGE ADAPTOR

623/10-005

Tensile connection for PE pipes, PN16, DN90-DN315

AVK Supa Plus™ is a range of tensile couplings, flange adaptors and end caps for connection to PE100 pipes. Supa Plus™ couplings are very easy to use due to the compression gasket that enables $\pm 3.5^\circ$ angular deflection and provides sufficient clearance that allows easy insertion of the pipe even in the larger dimensions. The M16 bolts of anti-friction coated stainless steel and the high quality epoxy coating offer durable corrosion protection.

Product description:

Supa Plus flange adaptor for PE pipes, with A4 nuts and bolts. For drinking water and neural liquids to max. 70C

Standards:

- Designed to: AS/NZS 4129
- Flange drilling to AS 2129 Table D/E

Test/Approvals:

- Connection certified to AS/NZS 4129
- StandardsMark approved to AS/NZS 4129
- WaterMark approved to AS/NZS 4129

Features:

- The combined gasket of drinking water approved EPDM rubber with tensile grip segments of RG5 bronze enables $\pm 3.5^\circ$ angular deflection
- The external bolt design prevents corrosion between the coupling body and bolts
- The M16 bolts of stainless steel A4 and the nuts of acid resistant stainless steel A4 are anti-friction coated to offer easy tightening and to prevent galling
- Bolt ends are protected with plastic caps to prevent damage of the thread during handling
- The gasket dimension allows sufficient clearance to ensure easy installation of the pipe, even in large diameters
- Body and bracket of ductile iron with fusion bonded epoxy coating in compliance with AS/NZS 4158

Accessories:

- Compliance to AS/NZS 4129 requires the use of a series 05 support bush to be fitted to the PE pipe end when using Supa Plus™ fittings and valves
- SDR11 support bush is provided as standard



Expect ... **AVR**

The designs, materials and specifications shown are subject to change without notice. This is due to the continuous development of our product range.

AVK SUPA PLUS™ FLANGE ADAPTOR

Tensile connection for PE pipes, PN16, DN90-DN315

623/10-005

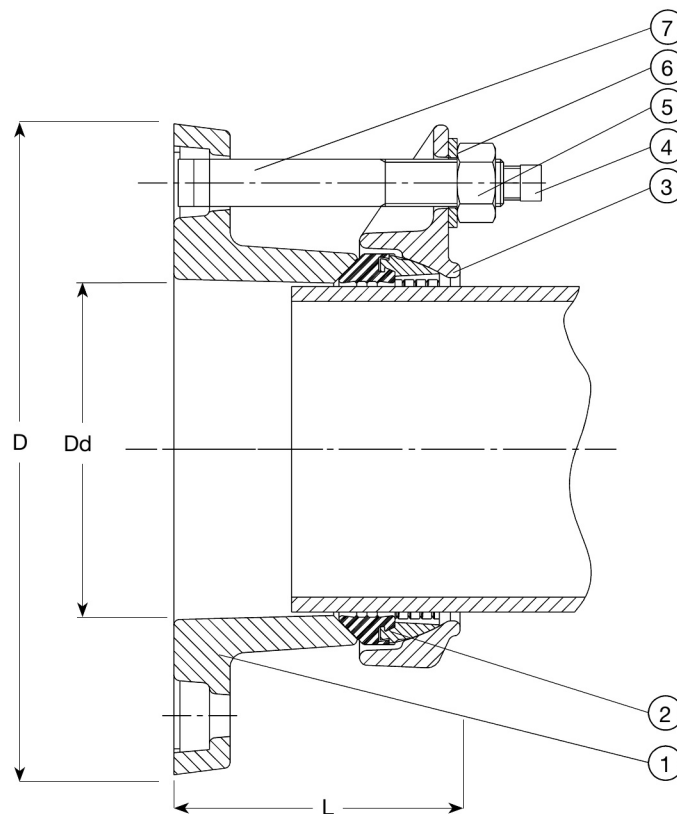

Component list:

1. Tensile sealing ring	Gunmetal bronze	5. Washer	Stainless steel A4
2. Adaptor flange	Ductile iron	6. Bolt	Stainless steel A4
3. Bracket	Ductile iron	7. Cap	Plastic
4. Hex Nut	Stainless steel A4, PTFE coated		

Components may be substituted with equivalent or higher class materials without prior notification.

Reference nos. and dimensions:

AVK ref. no.	DN mm	Dd mm	D mm	L mm	Flange drilling	Theoretical weight/kg
623-10-090-0541125	80	90	90	62	AS 4087 B5	-
623-10-110-0541125	100	110	110	63	AS 4087 B5	7.0
623-10-125-0241125	100	125	125	63	AS 4087 B5	7.0
623-10-125-0541125	125				BS10 D	8.0
623-10-160-0541125	150	125	160	63	AS 4087 B5	9.0
623-10-180-0541125	150	180	180	63	AS 4087 B5	11
623-10-200-0541125	200	200	200	64	AS 4087 B5	-
623-10-225-0541125	200	225	225	88	AS 4087 B5	-
623-10-250-0541125	250	250	250	88	AS 4087 B5	-
623-10-250-0641125	250	250	250	88	AS2129 E	-
623-10-280-0541125	250	280	280	88	AS 4087 B5	-
623-10-280-0641125	250	280	280	88	AS2129 E	-
623-10-315-0541125	300	315	315	88	AS 4087 B5	27

The designs, materials and specifications shown are subject to change without notice. This is due to the continuous development of our product range.