



## AVK SUPA PLUS™ COUPLING

621/41-003

Tensile connection for PE pipes, PN16, DN90-DN315

AVK Supa Plus™ is a range of tensile couplings, flange adaptors and end caps for connection to PE100 pipes. Supa Plus™ couplings are very easy to use due to the compression gasket that enables  $\pm 3.5^\circ$  angular deflection and provides sufficient clearance that allows easy insertion of the pipe even in the larger dimensions. The M16 bolts of anti-friction coated stainless steel and the high quality epoxy coating offer durable corrosion protection.

### Product description:

Supa Plus coupling, tensile for PE pipes with A4 nuts and bolts. For drinking water and neural liquids to max. 70C

### Standards:

- Designed to: AS/NZS 4129
- Coating to AS/NZS 4158

### Test/Approvals:

- Connection certified to AS/NZS 4129
- StandardsMark approved to AS/NZS 4129
- WaterMark approved to AS/NZS 4129

### Features:

- The combined gasket of drinking water approved EPDM rubber with tensile grip segments of RG5 bronze enables  $\pm 3.5^\circ$  angular deflection
- The external bolt design prevents corrosion between the coupling body and bolts
- The M16 bolts of stainless steel A4 and the nuts of acid resistant stainless steel A4 are anti-friction coated to offer easy tightening and to prevent galling
- Bolt ends are protected with plastic caps to prevent damage of the thread during handling
- The gasket dimension allows sufficient clearance to ensure easy installation of the pipe, even in large diameters
- Body and bracket of ductile iron with fusion bonded epoxy coating in compliance with AS/NZS 4158

### Accessories:

- Compliance to AS/NZS 4129 requires the use of a series 05 support bush to be fitted to the PE pipe end when using Supa Plus™ fittings and valves
- Support bushes are available for PE100 pipe manufactured in accordance with AS/NZS 4130, in SDR's 11,13.6 and 17
- SDR11 support bush is provided as standard



Expect... **AVR**

The designs, materials and specifications shown are subject to change without notice. This is due to the continuous development of our product range.

# AVK SUPA PLUS™ COUPLING

621/41-003

Tensile connection for PE pipes, PN16, DN90-DN315

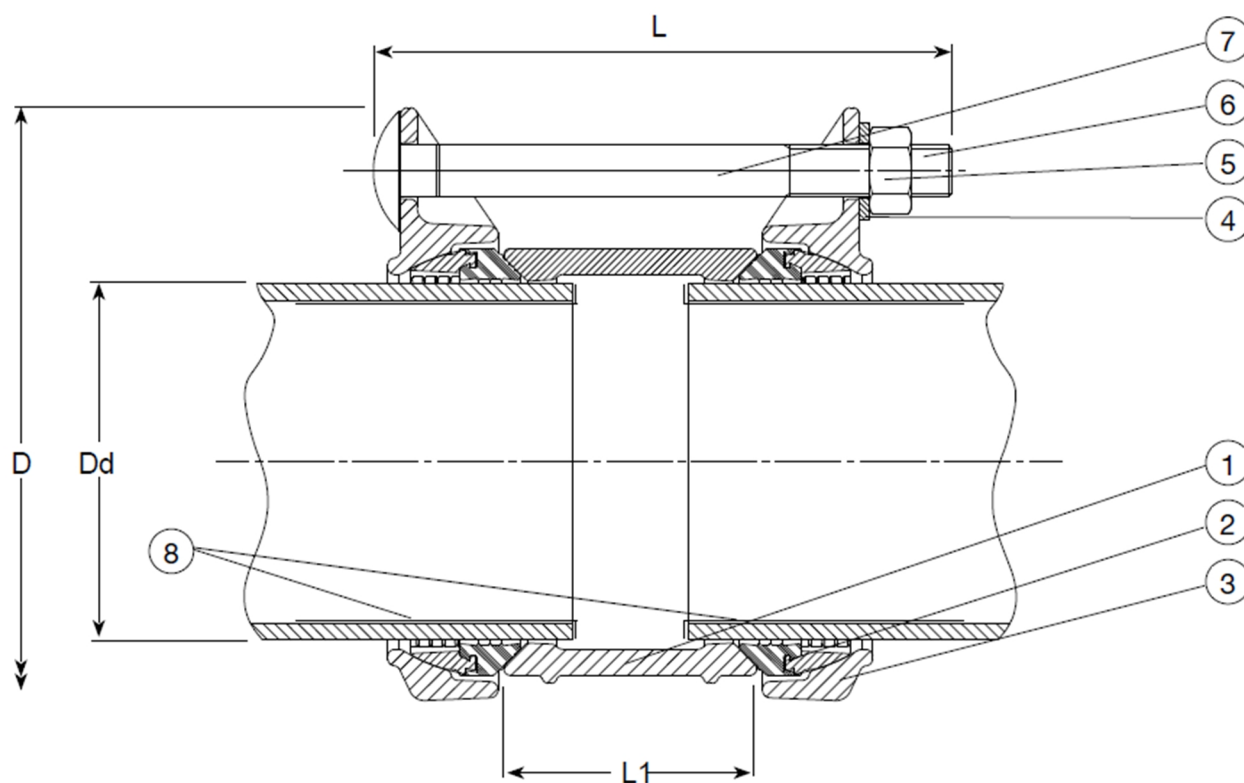

## Component list:

1. Body	Ductile iron	5. Nut	Stainless steel A4
2. Combined gasket	Bronze RG5 / EPDM	6. Cap	Plastic
3. Bracket	Ductile iron	7. Square bolt	Stainless steel A4
4. Washer	Stainless steel A4	8. Support bushing	Stainless steel 316

Components may be substituted with equivalent or higher class materials without prior notification.

## Reference nos. and dimensions:

AVK ref. no.	DN	Dd	D	Product	L	L1	Theoretical weight / kg
	mm	mm	mm	PN Class	mm	mm	
621-10-090-41125	80	90	200	PN16	160	70	6
621-10-110-41125	100	110	220	PN16	175	78	6
621-10-125-41125	125	125	240	PN16	175	78	9
621-10-140-41125	125	140	254	PN16	185	88	9.5
621-10-160-41125	150	160	276	PN16	185	88	11
621-10-180-41125	150	180	286	PN16	245	110	15
621-10-200-41125	200	200	318	PN16	210	110	13
621-10-225-41125	200	225	342	PN16	260	110	19
621-10-250-41125	250	250	374	PN16	260	110	26
621-10-280-41125	250	280	390	PN16	260	110	30
621-10-315-41125	300	315	440	PN16	320	168	36

The designs, materials and specifications shown are subject to change without notice. This is due to the continuous development of our product range.