



AVK SUPA-GIB END CAP, DN80-DN300

605/50-001

DI Body, A4 Fasteners, NBR Seal, PN16

Variable supra-gib blank end for use on Cast Iron, Ductile Iron, Steel, PVC-U, PVC-M, PVC-O, AC and Copper pipes.
Manufactured by AVK WANG

Product description:

Supra-gib blank end for water and sewer application to max. 60c

Standards:

- All materials AS/NZS 4020 compliant
- Manufactured in accordance with AS/NZS 4998

Features:

- For water and sewer applications to max 60°C
- Angular deflection of ± 3 degrees (total 6 degrees)
- 16 bar / 160 meters allowable operating pressure (AOP)
- Non restrained



Expect ... **AVR**

The designs, materials and specifications shown are subject to change without notice. This is due to the continuous development of our product range.

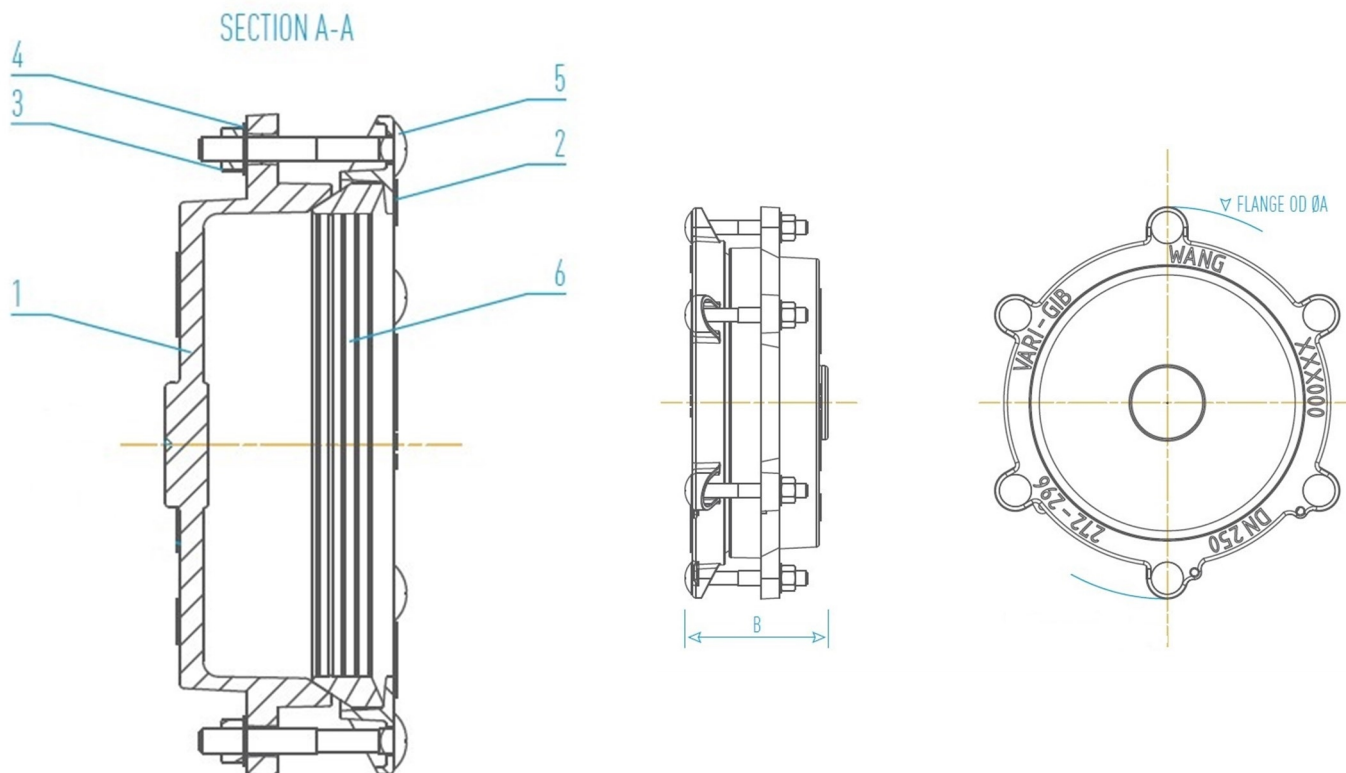

Component list:

1. Body	Ductile iron	4. Washer	Stainless steel 316
2. Flange	Ductile iron	5. Bolt	Stainless steel A4
3. Nut	Stainless steel A4, PTFE coated	6. Seal	NBR rubber

Components may be substituted with equivalent or higher class materials without prior notification.

Reference nos. and dimensions:

AVK ref. no.	DN mm	Product PN Class	Seal range mm	A mm	B mm	Number of bolts
605-5-103	80	PN16	88-103	238	140	3
605-5-133	100	PN16	109-133	263	150	3
605-5-182	150	PN16	158-182	312	150	4
605-5-238	200	PN16	214-238	371	150	5
605-5-264	225	PN16	240-264	399	150	5
605-5-296	250	PN16	272-296	431	150	6
605-5-334	300	PN16	310-334	490	220	6
605-5-354	300	PN16	330-354	510	220	6