

Responsive

AquaFast

Couplings & Flange Adaptors

For Polyethylene & PVC Connections

NOW
AVAILABLE
355 TO 450
DIAMETER

FITS MULTIPLE SDRS

QUICK & EASY FITTING
ON OVAL PIPES

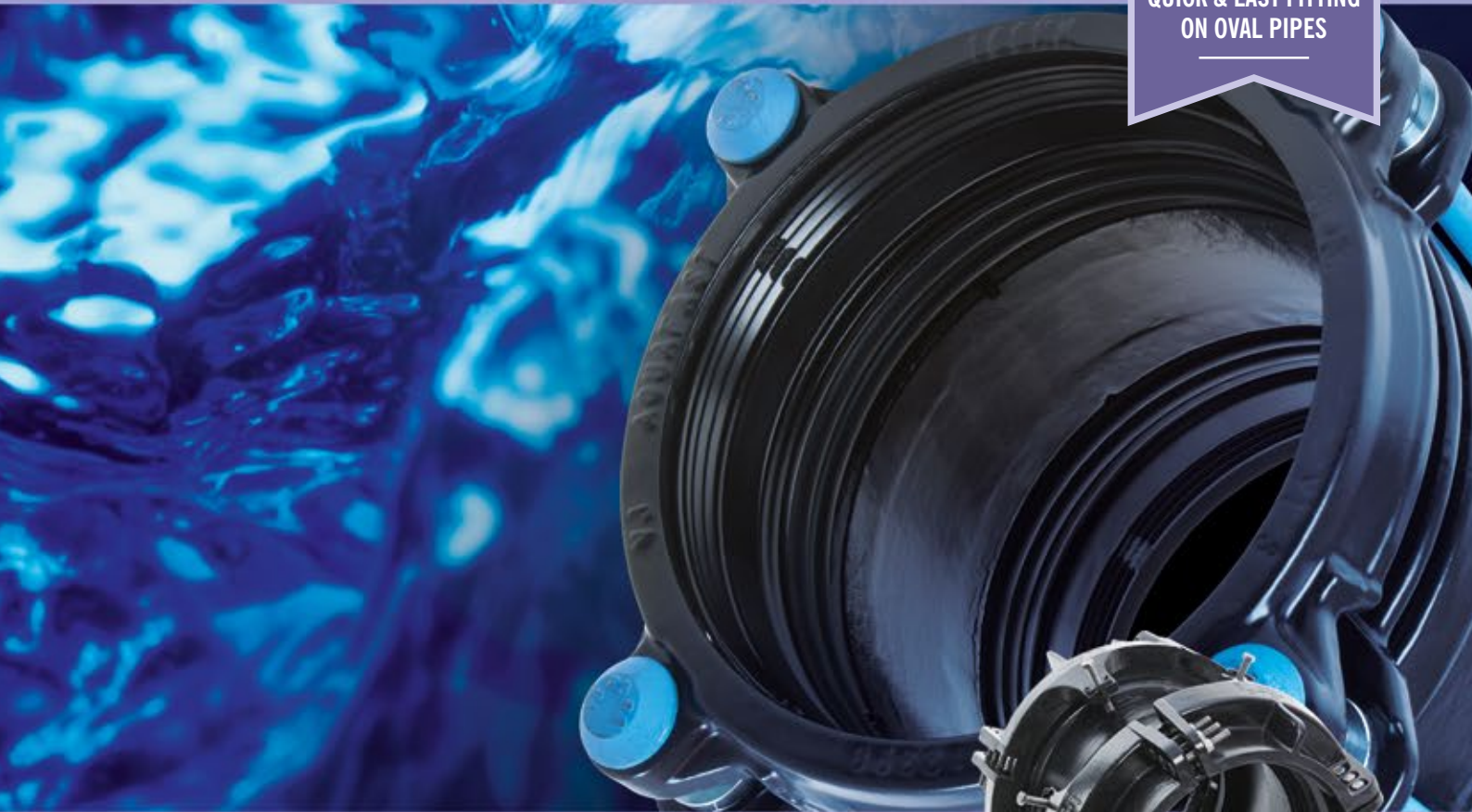

PIONEERS IN PIPE SOLUTIONS



Designed & Engineered to Simplify Polyethylene & PVC Pipe Connections

Effortless Installation

AquaFast's unique pressure sealing system offers a simple and reliable solution for connecting Polyethylene & PVC pipe. With a visual indicator confirming correct fitment and no special skills or tools required, installing AquaFast is effortless and quicker than other systems. In addition, an enhanced gripping mechanism ensures fittings slide easily into position during installation and provide full end load restraint in service negating the need for thrust blocks to prevent pipe pull out.



On-the-spot Repairs

From start to finish, AquaFast offers benefits to the installer. Supplied fully assembled and with an improved design that delays gripper engagement, AquaFast slides effortlessly over coiled and oval pipe making it easy for installers to correctly position the product in narrow trench conditions. Needing no specialist equipment, simply a "rag and a spanner", AquaFast can be installed in all-weather conditions and this, coupled with a design that does not need a support liner, means the product is ideal for on-the-spot connections in both new lay and repair / maintenance work.

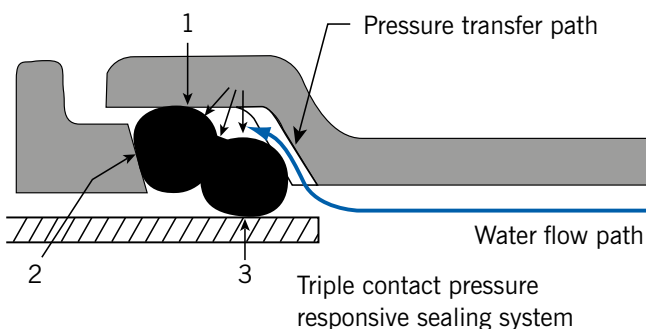

Note: All water contact materials approved for use with potable water by WRAS.

Simple Jointing

Using only a standard spanner to tighten fewer bolts (only two per fitting up to 125mm) until the visual indicator confirms correct fitment AquaFast provides operatives with simple means of joining PE pipes. The metal-to-metal positive stop indicating mobilisation of the gripper and gasket sealing mechanisms removes the need for a torque wrench and prevents over tightening of the bolts while ensuring optimum assembly to every time.

Transitional Connections

AquaFast couplings & flange adaptors are available from 63mm to 315mm OD. Designed to work on both Polyethylene pipe in both PE80 and PE100 material SDR 11, 17/17.6 without a support liner, they can also be used to connect metric PVC pipe, so AquaFast is ideal for PE/PVC transitional connections.

AquaFast Coupling



AquaFast Flange Adaptor

Pipe Materials



AquaFast Couplings & Flange Adaptors 63mm to 315mm

Product Design Benefits

Simple to Install

- Captive, non-rotating bolts across whole range requiring a single spanner to install.
- Increased bore dimensions and inclusion of resistors to prevent early engagement of gripper ensures AquaFast slides easily over pipe.



Positive Stop

- Correct installation confirmed through visual indication with metal to metal contact between three components (end ring, intermediate ring and sleeve / flange adaptor body).



Flexible Flange Drilling

- As standard the flange adaptors are multi drilled to accommodate BS EN 1092-1 PN10 & 16.

Efficient Gasket Sealing Technology

- Double 'O' ring gasket provides localised high pressure contact points generating efficient seal on pipe surface.
- EPDM (water quality approved) gaskets.

Corrosion Protection

- Metal components are coated with Rilsan Nylon 11, which is WRAS approved for use with potable water, and offers long term corrosion protection impact abrasion resistance.
- The nuts & bolts are Sheraplex coated to WIS 4-52-03, which does not gall when re-used and provides long term corrosion protection.

Unique Progressive Sealing and Gripping Mechanism

- Patented gasket and gripper design delivers low pressure / load to outside of pipe at initial bolt up eliminating the need for support liner.
- Water transfer path uses internal pressure to increase gasket compression at contact points.
- As system pressure increases the initial gripper engagement with the pipe is enhanced through progressive gripping.

Customer Benefits

- Ideal for pumped sewage line as no support liner is required meaning a clear unrestricted bore. Additionally, Rilsan abrasion resistance coating accommodates any solids any solids in sewage.
- 50 years design life expectancy is assured through "Accelerated Aging Testing" that simulates lifecycle of the product and Rilsan Nylon coating to metal works for corrosion protections as well as Sheraplex coated bolts to WIS 4-52-03.
- Rough on site handling accommodated by Rilsan coating.
- Simple onsite installation as the product comes pre-assembled hence easily slides over the round pipe. The resistor ensures gripper remains fully contained in housing until bolt up is complete.
- Reduced number of bolts ensures the product can be always orientated to facilitate easy access for bolt up.
- Minimal damage to pipe as progressive gripping system only penetrates sufficiently to mobilise and load forces from internal pressure and other loads in PE Pipe.
- All water contact materials approved for use with potable water (WRAS).
- Fully restrained fitting, designed to meet the performance requirements of WIS4-24-01 Type 2 and ISO17885.



Flange Adaptor

Designed for simplified & dependable trench installation every time.

Simple to Install

AquaFast Large Diameter is quick and easy to install providing an alternative solution to electrofusion and butt fusion for all weather and trench conditions. It is a simple fit and forget installation designed with the minimum number of bolts and without the need for an internal liner or expensive trench equipment.

Quality

Patents are pending on this innovative product designed and manufactured under quality systems to BS EN ISO 9001 and the requirements of UK & European Water Regulations.

Reduced Stock Holding

And now just 10 sizes will cover a range of multiple SDR's offering a significant reduction in traditional stockholding and allowing distributors and water utilities opportunity to have stock to cover all eventualities with off-the-shelf availability.

Innovative Design ideal for Oval Pipes



Viking Johnson has built in a high tolerance for AquaFast to fit with oval pipes and negating the need to utilise expensive and time consuming re-rounding tools.

Fully Corrosion Protected

WRAS approved black Rilsan Nylon 11 coating provides excellent corrosion and damage resistance to impact, abrasion, weathering and chemicals.

Resists Pull-out

Improved gripping mechanism offers end load restraint, resisting pipe pull out, allowing the coupling and flange adaptor to be suitable for use in climatic regions where temperatures range from -20°C up to 60°C. AquaFast has been designed to meet the performance requirements of BS EN 12842, WIS 4-24-01 Type 2 and ISO 17855 (supersedes ISO 14236.2)



Pipe Material

AquaFast Large Diameter Couplings & Flange Adaptors 355mm to 450mm

Product Design Benefits



Innovative Gripping

An enhanced gripping mechanism offers Type 2 end load restraint, resisting pipe pull out.



Corrosion Protection

All cast components are fully coated in Black Rilsan Nylon 11 which has excellent resistance to impact, abrasion, weathering and chemicals as well as good thermal stability and flexibility to accommodate for rough site handling.



Positive Stop

Correct installation confirmed through visual indication with metal to metal contact between the clamp bands.

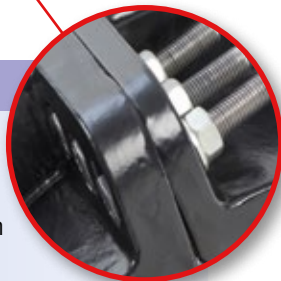

Centralisation Feature

Centralisation bolts are available around the product allowing accurate fitment during installation.



Customer Benefits

- ▶ Coupling can be used for repair - no internal restriction ideal for Sewage applications.
- ▶ Suitable for connecting pipes in wet/submerged conditions and above ground applications.
- ▶ No requirement for a support liner, torque wrench or any other specialist equipment on site.
- ▶ Easy to centralise on the pipe.
- ▶ Reduced stockholding - One product can connect one nominal pipe size with common SDRs (11, 17/17.6 and 21).
- ▶ 50 years design life expectancy.
- ▶ Reusability - No spares required for multiple installations.
- ▶ Saves time and effort as Contractor only has to identify PE pipe nominal size to select correct fitting.
- ▶ Fittings comes fully assembled.
- ▶ Minimal number of bolts to tighten.



United Kingdom - A14

Cambridge to Huntingdon A14

AquaFast Couplings up to DN355



Project

£1.5 billion investment to decommission a number of existing potable water and foul water pipelines which the new carriageway will be built over and put in place over 22km of new pipelines to ensure Anglian Water can continue to provide services to its customers.

Client

Anglian Water

Crane BS&U are solely the provider of products and have no direct influence on, or take any responsibility for any working practices employed or depicted in the images enclosed to install such products.



AquaFast Couplings 63mm to 315mm

Datasheet

1/2

Coupling

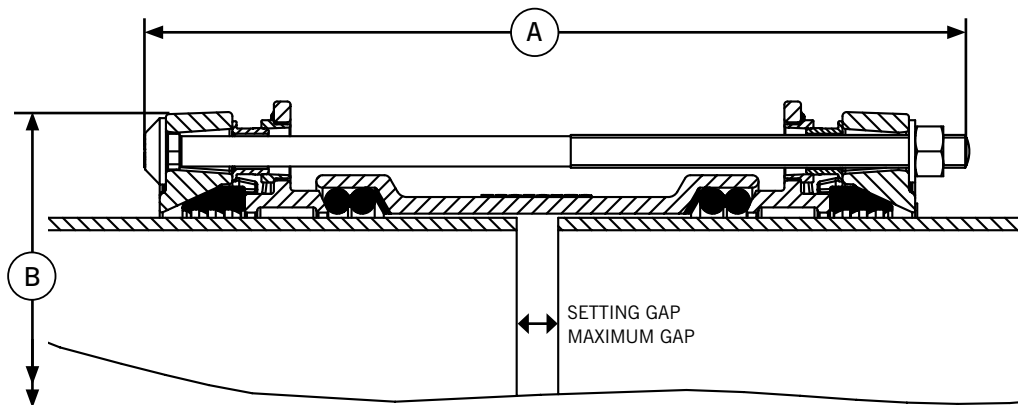

AquaFast Couplings

Pipe OD	Bolt Size No.-Dia x Length	Dimensions (mm)		Setting Gap (mm)	Max Gap (mm)	Weight (kg)
		A max	B dia			
63	2-M12 x 250	257	144	20	30	4.2
75	2-M12 x 250	257	156	20	30	4.7
90	2-M12 x 250	257	171	20	30	5.3
110	2-M12 x 250	257	192	20	30	6.4
125	2-M12 x 250	257	207	20	30	7.1
140	4-M12 x 250	257	221	20	30	8.4
160	4-M12 x 250	257	241	20	30	9.2
180	4-M12 x 375	382	272	30	50	18.0
200	4-M12 x 375	382	292	30	50	20.4
225	4-M16 x 385	395	328	30	50	24.8
250	6-M16 x 385	395	352	30	50	31.5
280	6-M16 x 385	395	382	30	50	33.6
315	6-M16 x 385	395	417	30	50	38.7

Every effort has been made to ensure that the information contained in this publication is accurate at the time of publishing. Crane Ltd assumes no responsibility or liability for typographical errors or omissions or for any misinterpretation of the information within the publication and reserves the right to change without notice.

DR8550_03_2020_ISSUE 6

AquaFast Couplings 63mm to 315mm

Datasheet

2/2

Technical Information

Working Pressure Rating

Water 16 bar

Gas not approved

Vacuum Pressure

Capable of accommodating a vacuum pressure of -0.7 bar

Site Test Pressure

1.5 times working pressure for short duration (2 hours)

Pipe Material / Support Liner

When used on the following pipe materials AquaFast does not need a support liner:-

- MDPE (PE80) and HPPE (PE100) in SDR ratings 11 & 17
- MOPVC (16 bar rated pipe)

Angularity

Couplings 1.5°

Bolt Torque/Spanner

Torque; None, simply tighten until correct installation confirmed through visual indication with metal to metal contact between three components (end ring, intermediate ring and sleeve).

Temperature Rating of Product

EPDM -20°C to +40°C

AquaFast is not suitable for use on heating systems with fluctuating temperatures.

End Load Due to Internal Pressure

AquaFast Fully restrained fitting, designed to meet the performance requirements of WIS4-24-01 Type 2 and ISO17885.

Approvals

The following water contact materials used in AquaFast are approved for use with potable water:-

Rilsan Nylon 11:

- WRAS, AS/NZS 4020, DVGW, W270, ACS & KIWA

EPDM Gaskets:

- WRAS, AS/NZS 4020

In addition to the above, AquaFast as a finished product has KIWA certification verifying that the above products comply with the requirements of the Water Supply (Water Fittings) Regulations for England and Wales 1999, the Water Byelaws 2000, Scotland and the Water Regulations Northern Ireland.

Materials & Relevant Standards

Centre Sleeve, End Ring & Flange Adaptor Body

Ductile iron to BS EN 1563 Symbol EN-GJS-450-10

Gripper Ring

Ductile iron to BS EN 1563 Symbol EN-GJS-450-10

Intermediate Ring

Ductile iron to BS EN 1563 Symbol EN-GJS-450-10

Gasket (EPDM)

BS EN 681-1 Type WA/BS 6920 hardness to 70 IRHD

Resisters

Free cutting Mild Steel (Grade Y15) Zn³ Zinc coated

Bolts

BS EN ISO 898-1 Property class 8.8

Option - Stainless Steel BS EN ISO3506-1 Grade A2 Property Class 70

(Stainless steel available as special order)

Nuts

Steel to BS EN20898-2 Property Class 8

Option - Stainless Steel BS EN ISO3506-2 Grade A4 Property Class 80

(Stainless steel available as special order)

Washers

BS 1449:Part 2 Grade 304S15

Coatings

Centre Sleeve, End Ring, Flange Adaptor body & intermediate ring:

- Rilsan Nylon 11

Gripper:

- Cathaphoretic coating

Bolts & Nuts:

- Sheraplex to WIS 4-52-03

Every effort has been made to ensure that the information contained in this publication is accurate at the time of publishing. Crane Ltd assumes no responsibility or liability for typographical errors or omissions or for any misinterpretation of the information within the publication and reserves the right to change without notice.

AquaFast Large Diameter Couplings 355mm to 450mm

Coupling

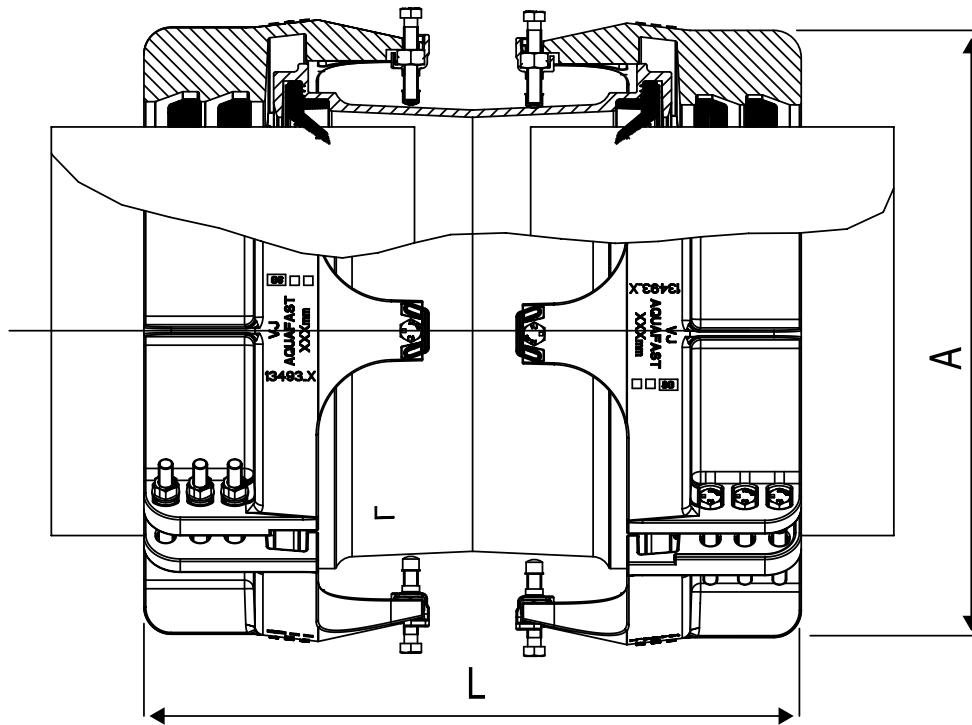

AquaFast Couplings

Nominal Size	Working Pressure (water) bar	Bolts size No dia x length	Insertion Depth (mm)	Setting gap (based on nominal insertion depth)	Outer Dimensions (mm)			Weight (kg)
					Clamp band outer diameter (A)		Length (L)	
					Installed	Uninstalled		
355	16	24-M16 x 120	241	210	540	571	692	213.3
400	16	24-M16 x 120	247	210	585	618	704	231.3
450	16	24-M16 x 120	255	210	635	670	720	253.3

Every effort has been made to ensure that the information contained in this publication is accurate at the time of publishing. Crane Ltd assumes no responsibility or liability for typographical errors or omissions or for any misinterpretation of the information within the publication and reserves the right to change without notice.

AquaFast Large Diameter Couplings 355mm to 450mm

Datasheet

2/2

Technical Information

Working Pressure Rating

Water 16 bar

Gas not approved

Vacuum Pressure

Capable of accommodating a vacuum pressure of -0.7 bar

Site Test Pressure

1.5 times working pressure for short duration (2 hours)

Pipe Material / Support Liner

When used on the following pipe materials AquaFast does not need a support liner:-

- ▶ MDPE (PE80) in SDR ratings 11 & 17/17.6
- ▶ HDPE (PE100) in SDR ratings 11, 17/17.6 & 21

Angularity (in accordance with BS EN 12842)

Couplings 1.0°

Bolt Torque/Spanner

Torque; None, simply tighten until correct installation confirmed
Correct installation confirmed through visual indication with metal to metal contact between the clamp bands.

Temperature Rating of Product

EPDM -20°C to +60°C

AquaFast is not suitable for use on heating systems with fluctuating temperatures.

End Load Due to Internal Pressure

AquaFast Fully restrained fitting, and has been designed to meet the performance requirements of BS EN 12842, WIS 4-24-01 Type 2 and ISO 17855 (supersedes ISO 14236.2).

Approvals

The following water contact materials used in AquaFast are approved for use with potable water:-

Rilsan Nylon 11:

- ▶ WRAS, AS/NZS 4020, DVGW, W270, ACS & KIWA

EPDM Gaskets:

- ▶ WRAS, AS/NZS 4020

In addition to the above, AquaFast as a finished product has KIWA certification verifying that the above products comply with the requirements of the Water Supply (Water Fittings) Regulations for England and Wales 1999, the Water Byelaws 2000, Scotland and the Water Regulations Northern Ireland.

Materials & Relevant Standards

Flange Adaptor Body, Centre Sleeve, Clamp Bands & Gripper Ring

Ductile iron to BS EN 1563 Symbol EN-GJS-450-10

Gasket

EPDM Grade 'E' to BS EN 681-1:1996 Type WA WRAS listed

Coatings

Body, Sleeve, Intermediate Ring & End Ring

- ▶ Rilsan Nylon 11 to WIS 4-52-01 Part 1

Nuts and Bolts:

- ▶ Sheraplex coated to WIS 4-52-03

Gripper:

- ▶ Cathaphoretic coating

Bolts

Standard - Stainless Steel BS EN ISO3506-1 Grade A2-70

Nuts

Standard - Stainless Steel BS EN ISO3506-2 Grade A4-80

Washers

Stainless Steel to BS1449: Part 2:1983 Grade 304S15

AquaFast Flange Adaptors 63mm to 315mm

Datasheet 1/2

Flange Adaptor

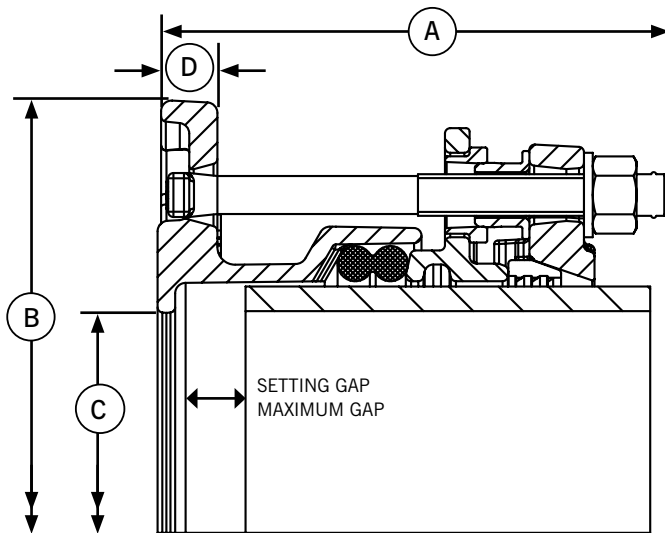

AquaFast Flange Adaptors

Pipe OD	Flange Drillings	Tee Bolt Size No.-Dia x Length	Dimensions (mm)		Bore C (mm)	Flange Thickness D (mm)	Setting Gap (mm)	Max Gap (mm)	Weight (kg)
			A max	B dia					
63	50/65 PN10,16	2-M12 x 135	144	185	50	17	20	25	4.4
75	65/80 PN10,16	2-M12 x 135	144	200	65	17	20	25	4.8
75	60 PN10,16	2-M12 x 135	144	200	65	17	20	25	4.9
90	65/80 PN10,16	2-M12 x 135	144	200	80	17	20	25	5.0
110	100 PN10,16	2-M12 x 135	144	229	100	17	20	25	6.1
125	100/125 PN10,16	2-M12 x 135	144	250	100	17	20	25	7.2
140	125 PN10,16	4-M12 x 135	144	250	125	17	20	25	7.4
160	150 PN10,16	4-M12 x 135	144	285	150	17	20	25	8.5
180	150 PN10,16	4-M12 x 190	199	285	150	17	25	35	12.4
200	200 PN10,16	4-M12 x 190	200	343	190	18	25	35	15.4
225	200 PN10,16	4-M16 x 195	205	343	190	18	25	35	16.9
250	250 PN10,16	6-M16 x 195	207	406	240	20	25	35	22.5
280	250 PN10,16	6-M16 x 195	207	406	270	20	25	35	22.1
315	300 PN10,16	6-M16 x 195	208	483	300	21.5	25	35	28.2

All flanges drilled to BS EN 1092-1 (formerly BS 4504) /BS EN ISO 7005 PN10 and PN16

Every effort has been made to ensure that the information contained in this publication is accurate at the time of publishing. Crane Ltd assumes no responsibility or liability for typographical errors or omissions or for any misinterpretation of the information within the publication and reserves the right to change without notice.

DR8550_03_2020_ISSUE 6

AquaFast Flange Adaptors 63mm to 315mm

Datasheet

2/2

Technical Information

Working Pressure Rating

Water 16 bar

Gas not approved

Vacuum Pressure

Capable of accommodating a vacuum pressure of -0.7 bar

Site Test Pressure

1.5 times working pressure for short duration (2 hours)

Pipe Material / Support Liner

When used on the following pipe materials AquaFast does not need a support liner:-

- MDPE (PE80) and HPPE (PE100) in SDR ratings 11 & 17
- MOPVC (16 bar rated pipe)

Flange Drilling

All flange drilled to BS EN 1092-1 (formerly BS 4504) /BS EN ISO 7005 PN10 and PN16

Angularity (in accordance with BS EN 12842)

Flange Adaptors 1.5°

Bolt Torque/Spanner

Torque; None, simply tighten until correct installation confirmed through visual indication with metal to metal contact between three components (end ring, intermediate ring and adaptor body).

Temperature Rating of Product

EPDM -20°C to +40°C

AquaFast is not suitable for use on heating systems with fluctuating temperatures.

End Load Due to Internal Pressure

AquaFast Fully restrained fitting, designed to meet the performance requirements of WIS4-24-01 Type 2 and ISO17885.

Approvals

The following water contact materials used in AquaFast are approved for use with potable water:-

Rilsan Nylon 11:

- WRAS, AS/NZS 4020, DVGW, W270, ACS & KIWA

EPDM Gaskets:

- WRAS, AS/NZS 4020

In addition to the above, AquaFast as a finished product has KIWA certification verifying that the above products comply with the requirements of the Water Supply (Water Fittings) Regulations for England and Wales 1999, the Water Byelaws 2000, Scotland and the Water Regulations Northern Ireland.

Materials & Relevant Standards

Centre Sleeve, End Ring & Flange Adaptor Body

Ductile iron to BS EN 1563 Symbol EN-GJS-450-10

Gripper Ring

Ductile iron to BS EN 1563 Symbol EN-GJS-450-10

Intermediate Ring

Ductile iron to BS EN 1563 Symbol EN-GJS-450-10

Gasket (EPDM)

BS EN 681-1 Type WA/BS 6920 hardness to 70 IRHD

Resisters

Free cutting Mild Steel (Grade Y15) Zn³ Zinc coated

Bolts

BS EN ISO 898-1 Property class 8.8

Option - Stainless Steel BS EN ISO3506-1 Grade A2 Property Class 70

(Stainless steel available as special order)

Nuts

Steel to BS EN20898-2 Property Class 8

Option - Stainless Steel BS EN ISO3506-2 Grade A4 Property Class 80

(Stainless steel available as special order)

Washers

BS 1449:Part 2 Grade 304S15

Coatings

Centre Sleeve, End Ring, Flange Adaptor body & intermediate ring:

- Rilsan Nylon 11

Gripper:

- Cathaphoretic coating

Bolts & Nuts:

- Sheraplex to WIS 4-52-03

Every effort has been made to ensure that the information contained in this publication is accurate at the time of publishing. Crane Ltd assumes no responsibility or liability for typographical errors or omissions or for any misinterpretation of the information within the publication and reserves the right to change without notice.

AquaFast Large Diameter Flange Adaptors 355mm to 450mm

Datasheet 1/2

Flange Adaptor

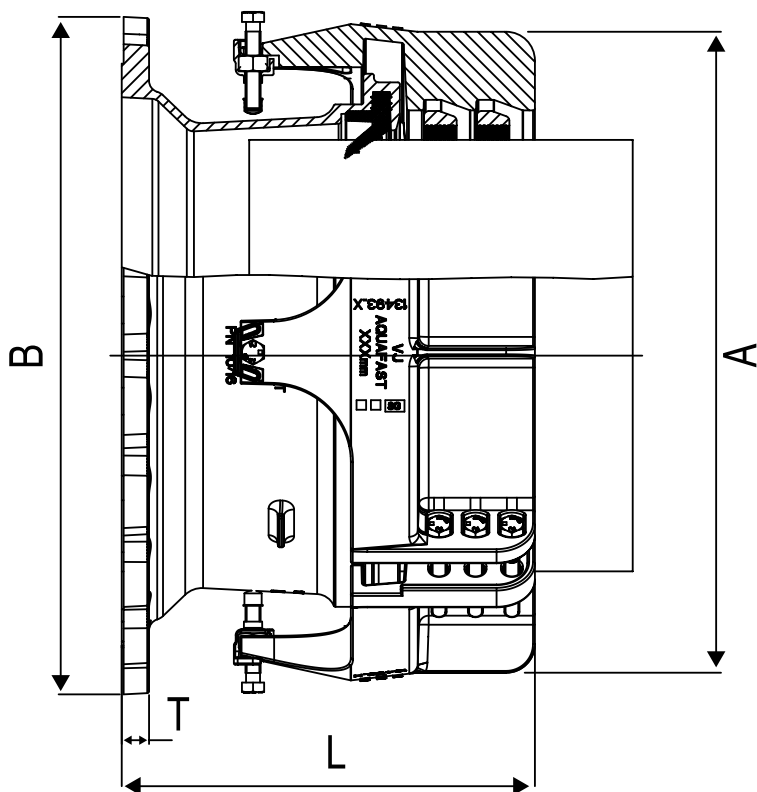

AquaFast Flange Adaptors

Nominal Size	Flange Drilling	Working Pressure (water) bar	Bolts size No dia x length	Insertion Depth (mm)			Setting gap (based on nominal insertion depth)	Outer Dimensions (mm)				Weight (kg)	
				Min	Nom	Max		Clamp Band Outer Diameter (A)		Length (L)	Flange Outer Diameter (B)		Flange Thickness (T)
								Installed	Uninstalled				
355	300 PN10,16	16	12-M16 x 120	284	304	324	197	540	571	501	455	22.5	122.2
355	350 PN10,16	16	12-M16 x 120	284	304	324	117	540	571	421	520	23.5	120.0
400	350 PN10,16	16	12-M16 x 120	289	309	329	183	585	618	492	520	23.5	134.4
400	400 PN10,16	16	12-M16 x 120	290	310	330	117	585	618	427	580	25	132.0
450	400 PN10,16	16	12-M16 x 120	298	318	338	109	635	670	427	580	25	142.9
450	450 PN10,16	16	12-M16 x 120	298	318	338	117	635	670	435	640	27	147.2
450	500 PN10,16	16	12-M16 x 120	298	318	338	117	635	670	435	715	28.5	155.4

Every effort has been made to ensure that the information contained in this publication is accurate at the time of publishing. Crane Ltd assumes no responsibility or liability for typographical errors or omissions or for any misinterpretation of the information within the publication and reserves the right to change without notice.

DR8550_03_2020_ISSUE 6

AquaFast Large Diameter Flange Adaptors 355mm to 450mm

Datasheet

2/2

Technical Information

Working Pressure Rating

Water 16 bar

Gas not approved

Vacuum Pressure

Capable of accommodating a vacuum pressure of -0.7 bar

Site Test Pressure

1.5 times working pressure for short duration (2 hours)

Pipe Material / Support Liner

When used on the following pipe materials AquaFast does not need a support liner:-

- ▶ MDPE (PE80) in SDR ratings 11 & 17/17.6
- ▶ HDPE (PE100) in SDR ratings 11, 17/17.6 & 21

Angularity (in accordance with BS EN 12842)

Flange Adaptors 1.0°

Bolt Torque/Spanner

Torque; None, simply tighten until correct installation confirmed
Correct installation confirmed through visual indication with metal to metal contact between the clamp bands.

Temperature Rating of Product

EPDM -20°C to +60°C

AquaFast is not suitable for use on heating systems with fluctuating temperatures.

End Load Due to Internal Pressure

AquaFast Fully restrained fitting, and has been designed to meet the performance requirements of BS EN 12842, WIS 4-24-01 Type 2 and ISO 17855 (supersedes ISO 14236.2).

Approvals

The following water contact materials used in AquaFast are approved for use with potable water:-

Rilsan Nylon 11:

- ▶ WRAS, AS/NZS 4020, DVGW, W270, ACS & KIWA

EPDM Gaskets:

- ▶ WRAS, AS/NZS 4020

In addition to the above, AquaFast as a finished product has KIWA certification verifying that the above products comply with the requirements of the Water Supply (Water Fittings) Regulations for England and Wales 1999, the Water Byelaws 2000, Scotland and the Water Regulations Northern Ireland.

Materials & Relevant Standards

Flange Adaptor Body, Centre Sleeve, Clamp Bands & Gripper Ring

Ductile iron to BS EN 1563 Symbol EN-GJS-450-10

Gasket

EPDM Grade 'E' to BS EN 681-1:1996 Type WA WRAS listed

Coatings

Body, Sleeve, Intermediate Ring & End Ring

- ▶ Rilsan Nylon 11 to WIS 4-52-01 Part 1

Nuts and Bolts:

- ▶ Sheraplex coated to WIS 4-52-03

Gripper:

- ▶ Cathaphoretic coating

Bolts

Standard - Stainless Steel BS EN ISO3506-1 Grade A2-70

Nuts

Standard - Stainless Steel BS EN ISO3506-2 Grade A4-80

Washers

Stainless Steel to BS1449: Part 2:1983 Grade 304S15

Every effort has been made to ensure that the information contained in this publication is accurate at the time of publishing. Crane Ltd assumes no responsibility or liability for typographical errors or omissions or for any misinterpretation of the information within the publication and reserves the right to change without notice.

DR9550_03_2020_ISSUE 6



France - Villiers Adam City

Making Drinking Water Systems More Reliable

AquaFast Flange Adapters

Project

Viking Johnsons AquaFast product has been selected to provide a bespoke solution for SETHA bobingy. AquaFast products have been selected due to their progressive sealing system and reusable benefits for pressure tests.

Client

SEDIF

Contractor

SETHA Bobingy (Sade)

Crane BS&U are solely the provider of products and have no direct influence on, or take any responsibility for any working practices employed or depicted in the images enclosed to install such products.

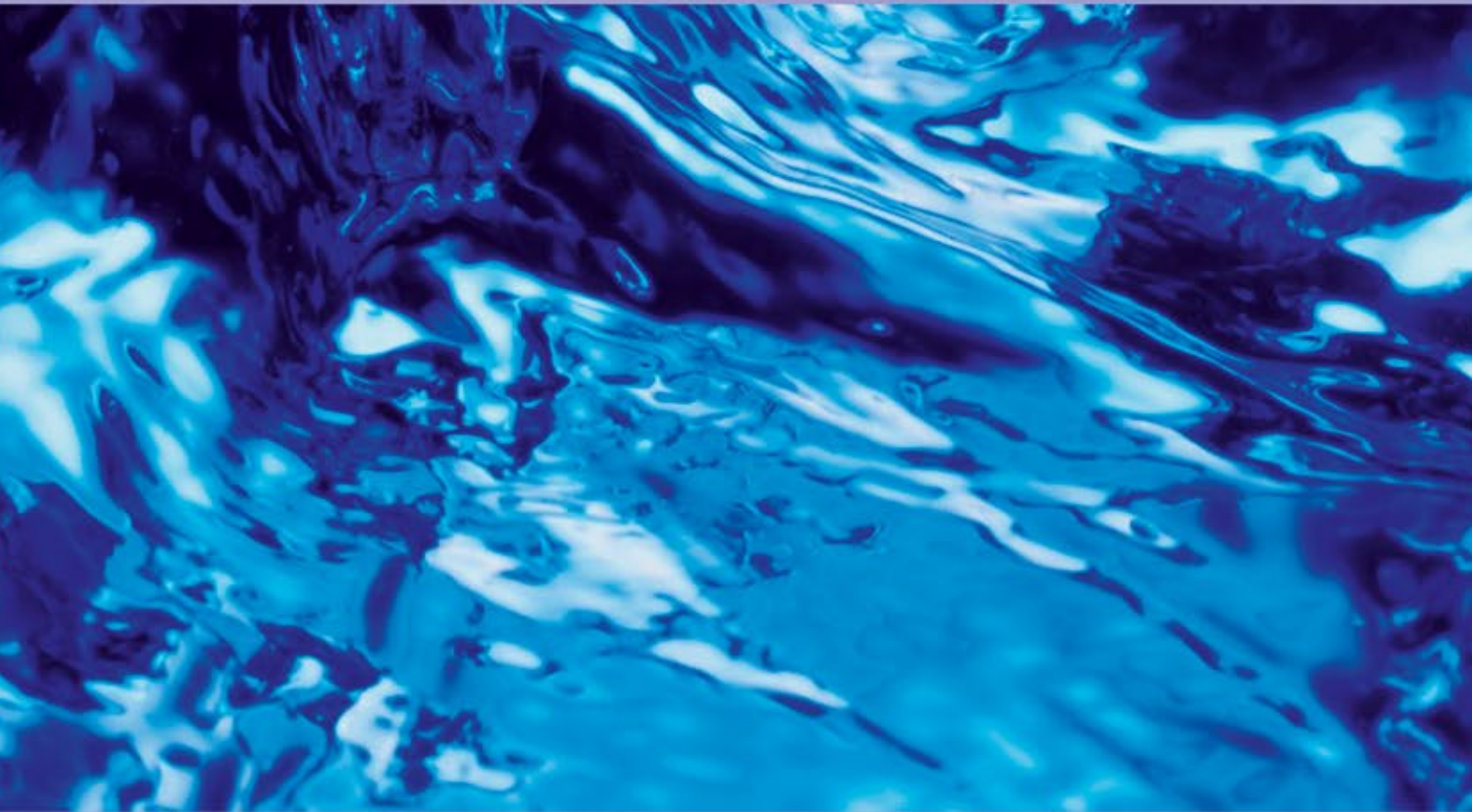

46-48 WILBURY WAY
HITCHIN, HERTFORDSHIRE
SG4 0UD. UNITED KINGDOM
TELEPHONE: +44 (0)1462 443322
FAX: +44 (0)1462 443311
EMAIL: info@vikingjohnson.com

www.vikingjohnson.com

DUBAI SALES OFFICE
CRANE BS&U
BUILDING 4, OFFICE 901
THE GALLERIES
PO BOX 17415
DOWNTOWN JEBEL ALI
DUBAI. UAE
TELEPHONE: +971 4816 5800



FM 00311

EMS 553775



To visit our Video Library go to:
www.youtube.com/user/CraneBSU

- Designed and manufactured under quality management systems in accordance with BS EN ISO 9001.
- Environmental Management System accredited to ISO 14001.
- For full terms and conditions, please visit our website.

Every effort has been made to ensure that the information contained in this publication is accurate at the time of publishing. Crane Ltd assumes no responsibility or liability for typographical errors or omissions or for any misinterpretation of the information within the publication and reserves the right to change without notice.

DR9560_03_2020_ISSUE 6

PIONEERS IN PIPE SOLUTIONS



BUILDING SERVICES & UTILITIES

www.cranesbu.com

